

REVISIONS				
ZONE	REV.	DESCRIPTION	DATE	APPROVED
	A	CUSTOMER INFORMATIONAL	08/10/2019	RA

D
C
B
A

D
C
B
A

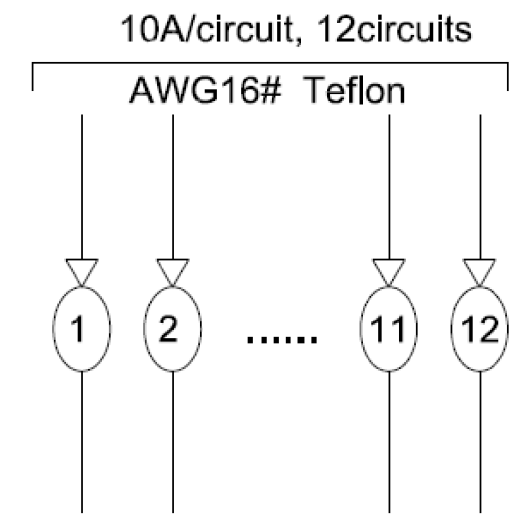
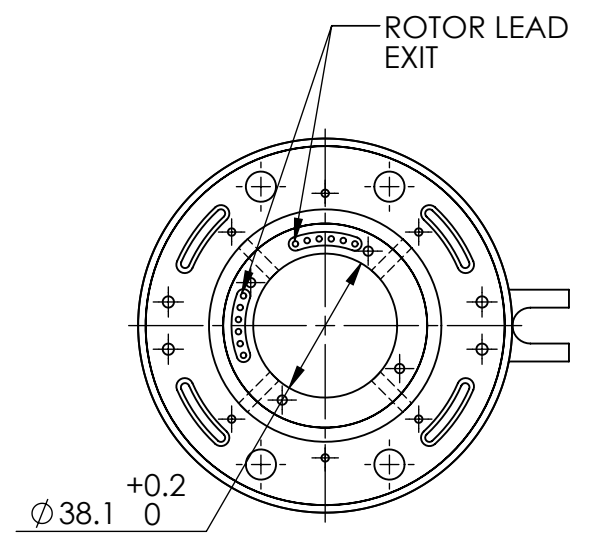
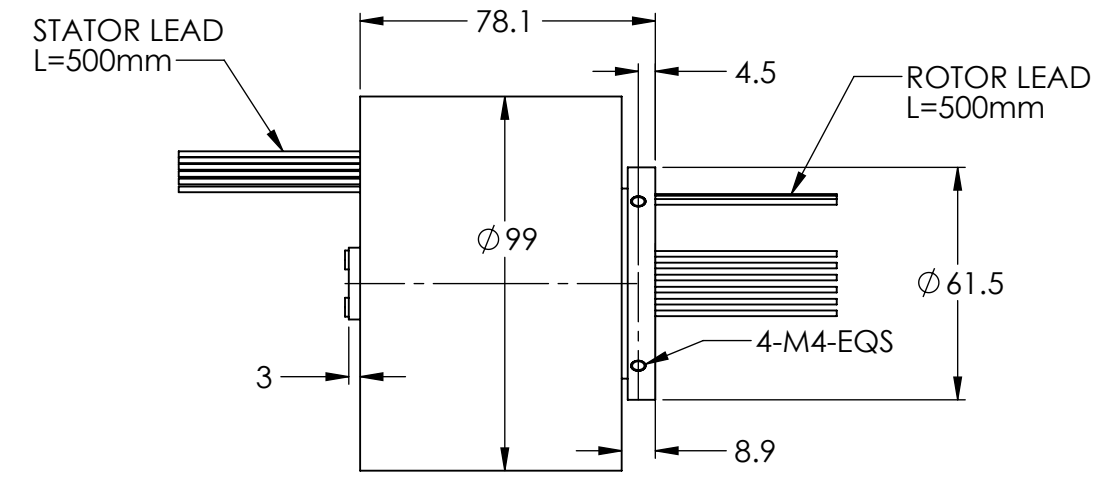
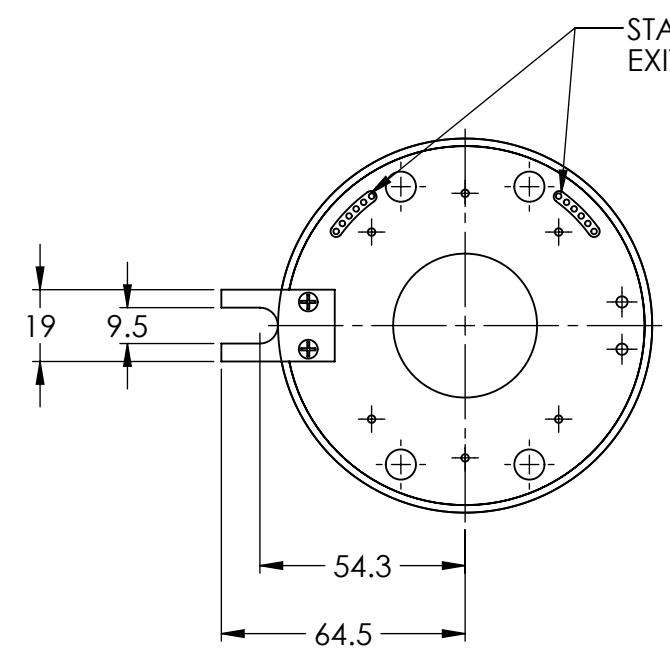

NOTE: FOR 15 AMP POWER CIRCUITS,ADD "-B" TO PART NUMBER

TECHNICAL DATA	
NUMBER OF CIRCUITS	12 POWER
RATED VOLTAGE	460 VAC
DIELECTRIC STRENGTH	500VAC @50Hz, 60s
RATED CURRENT (POWER)	10A
NOMINAL SPEED	250 RPM
INSULATION RESISTANCE	>500 M Ω /500 VDC
DYNAMIC CONTACT RESISTANCE	<10 m Ω
CONTACT MATERIAL SURFACE	PRECIOUS METAL
LEAD	TEFLON 16 AWG
LEAD LENGTH	500mm
TEMPERATURE	-20°C to + 80°C
BEARINGS	STAINLESS STEEL BEARINGS
HOUSING	ENGINEERED PLASTIC
PROTECTION	IP51

THIS DRAWING CONTAINS PROPRIETARY INFORMATION OF THE ORBEX GROUP AND MAY NOT BE IN WHOLE OR IN PART DUPLICATED OR DISCLOSED OR USED FOR MANUFACTURE OF ANY PART DISCLOSED HEREIN WITHOUT WRITTEN PERMISSION OF THE ORBEX GROUP.

CONFIDENTIAL

UNLESS OTHERWISE SPECIFIED: ANGLE: $\pm 0.5^\circ$	
LINEAR DIMENSION	
0.5-6	± 0.1
>6-30	± 0.2
>30-120	± 0.3
>120-400	± 0.5
>400-1000	± 0.8
>1000-2000	± 1.2
>2000-4000	± 2
MATERIAL	SEE CHART
FINISH	CLEAN
DRAWN	Sun KPO 08/10/2019

Orbex Group

TITLE:
SLIP RING

SIZE B	PRT. NO. 538-0012	REV A
SCALE: 1:1		SHEET 1 OF 1

8 7 6 5 4 3 2 1